

# Bolt Measurements Diagram

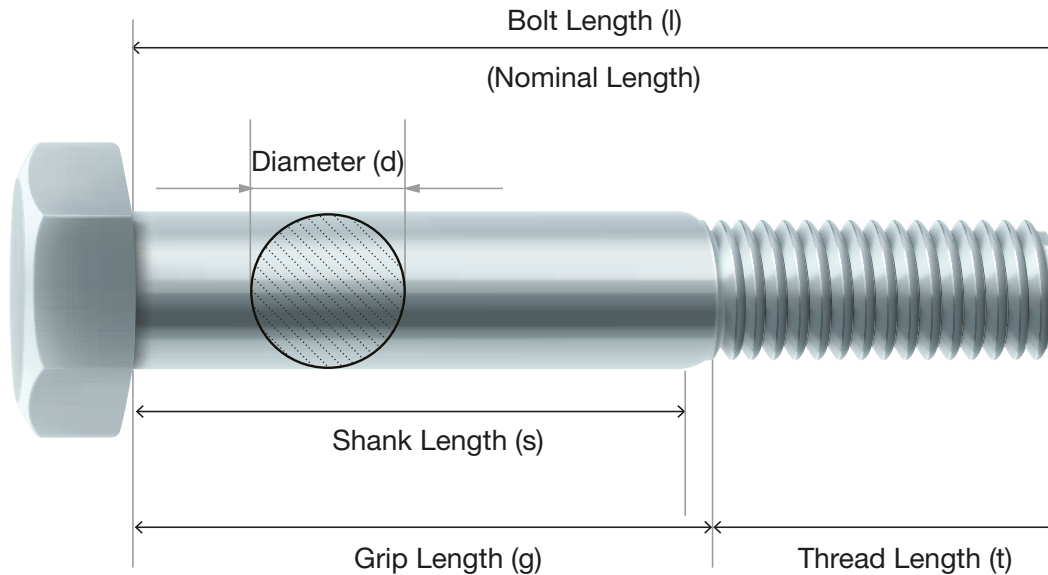

This resource outlines different bolt measurements and how to determine thread and shank lengths. These dimensions are important when you want to figure out strength and amount of thread engagement on the fastener.



## Formula To Calculate The Thread Length Of Partial Thread Bolts

A Guide For: DIN 931, ISO 4014

Bolts up to and including 125mm long:

$$t = 2d + 6$$

Bolts 130mm - 200mm long:

$$t = 2d + 12$$

Bolts 220mm and longer:

$$t = 2d + 25$$

Key:

**t** = Thread Length

**d** = Bolt Diameter

**l** = Bolt Length

**g** = Grip Length

**s** = Shank Length

Units in mm

Formula to calculate grip length:

$$g = s - t$$

① The data provided in this document is for general guidance only and should not be solely relied upon when working to stringent specifications. We recommend consulting with qualified experts regarding any technical queries. This information may change without written notice.